



OMEGAPRO

Catalog Number _____

Type _____

Job _____

The OB-2 Accent Light is perfect for upward illumination of an object to create dramatic, beautiful accents to trees, columns and other architectural features. Commonly used to create focal points in a landscape and shadows on walls.

ACCENT LIGHT
G4 LED

OB-2



SPECIFICATIONS



Model#	OB-2
Housing	Solid Brass
Lamp Base	GU5.3 bi-pin
Lamp	12V G4 (not included)
Max. Wattage	35W
Wiring	3' 18/2 UL wire, SPT-2W leads
Mounting Accesories	Small PVC Stake
Lens	Frosted or Clear tempered glass
Operation	-13°-104°F
Warranty	Limited Lifetime Warranty

Packing Information

Packing Content	(1) OB-2 Fixture (1) Small PVC stake
-----------------	---

DIMENSIONS

OB-2

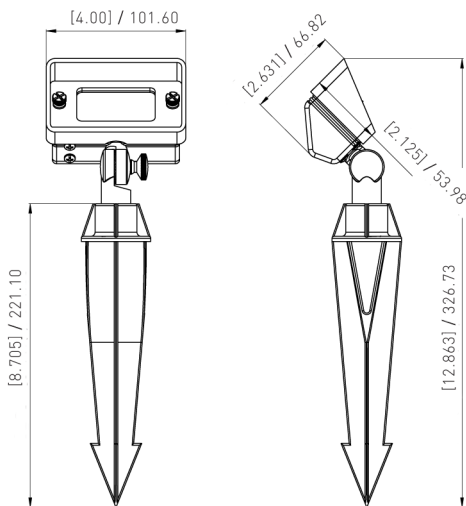

[inches] / millimeters