

4 in 1 RF+WiFi Gemini CSPG LED Controller

IC1009EATYW5C

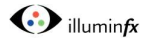

Important: Read All Instructions Prior to Installation

Function introduction

Dip switch for device mode selection; DIM, CCT, RGBW and RGB+CCT 4 modes are available, factory default is RGB+CCT mode

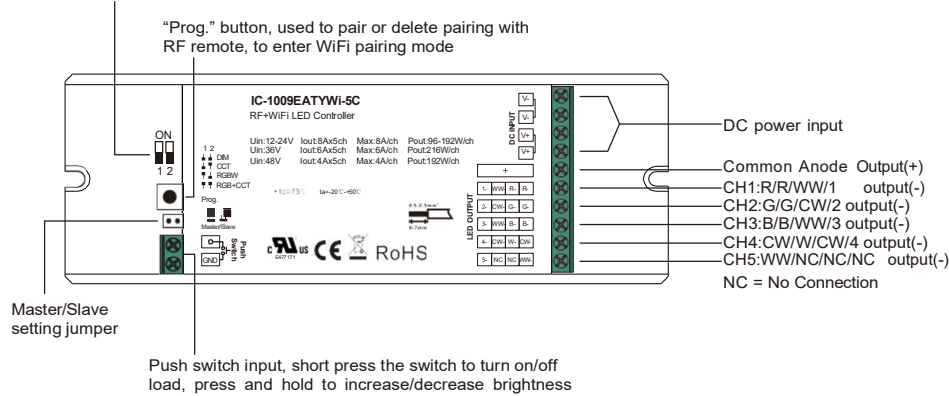

Product Data

Input Voltage	Output Current	Output Power	Connector Current Rating	Wire Size	Remarks	Size(LxWxH)	Ambient Temperature	Max. Casing Temperature
12-48VDC	Max. 8A/CH@12V/24V Max. 6A/CH@36V Max. 4A/CH@48V	Max. 96W/CH@12V Max. 192W/CH@24V Max. 216W/CH@36V Max. 192W/CH@48V	Max. 20A	0.05-3.3mm ² (12-30AWG)	Constant voltage	170x59x29mm	-20°C ~ +50°C	75°C

Product Features

- 4 in 1 RF+WiFi+Push Dim LED controller
- 5 channels 12/24V/36V/48V constant voltage output
- Max. 8A output per channel
- Enables to set the device type via DIP switches
- 4 device types are available for setting: DIM, CCT, RGBW, RGB+CCT
- Can be controlled through SmartLife APP
- Cloud control enabled based on SmartLife platform
- Voice control enabled, can be controlled through Amazon Alexa & Google Assistant
- Local control available through RF remotes even without WiFi network
- Sub-1GHz RF frequency: 434/869.6/916.5MHz
- Compatible with universal legacy RF remotes
- With push dim function, can be controlled through existing push switches even without WiFi and RF remotes
- Waterproof grade: IP20

Safety & Warnings

- DO NOT install with power applied to device.
- DO NOT set the DIP switches with power applied to device.
- DO NOT expose the device to moisture.

Operation

1. Do wiring according to wiring diagram.

2. Pair the WiFi LED controller to the smart phone or tablet:

Step 1: Download the "SmartLife" APP from APP store or google play, and register an account as instructed, then log in the account. **Please enable bluetooth on your smart phone in advance.**

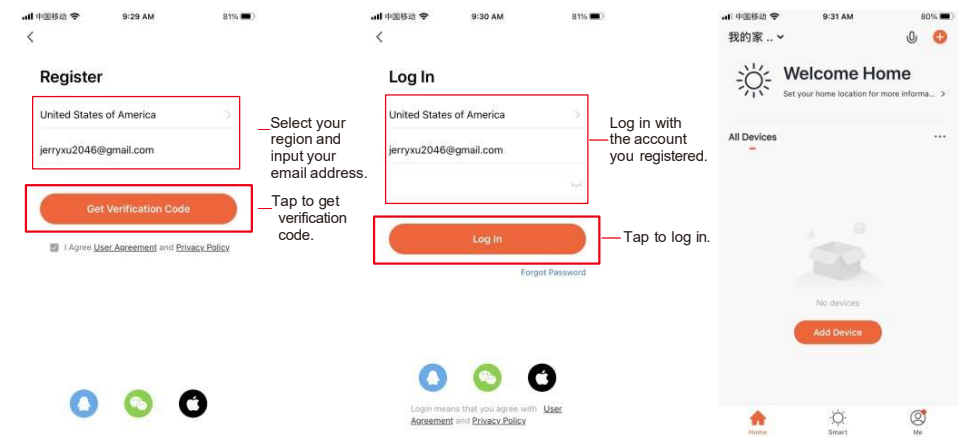

Step 2: Short press the "Prog" button 5 times continuously (or reset power of the controller 5 times) to reset the WiFi LED controller and set it to WiFi pairing mode, LED light will blink rapidly, then tap "Add Device" to pair the WiFi LED controller to the smart phone.



Step 3: Confirm that the driver is set to pairing mode and LED light blinks rapidly. Connecting starts, the WiFi LED controller will appear on the APP interface once added successfully.

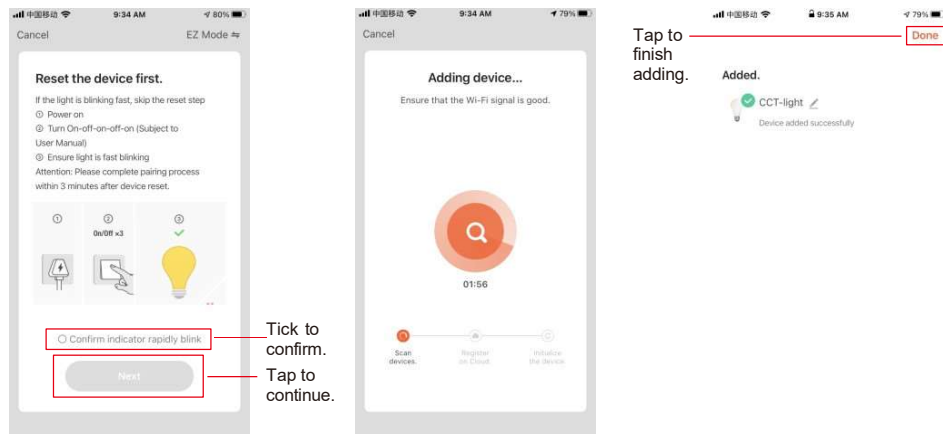

Step 4: You can control the WiFi LED controller through the APP.

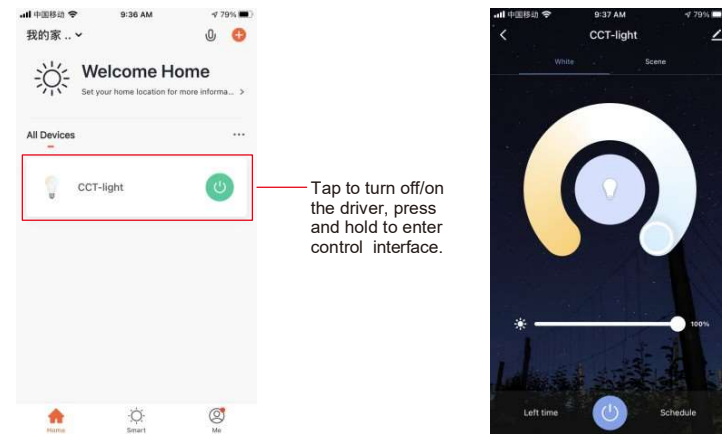

Step 5: Scene Setting.

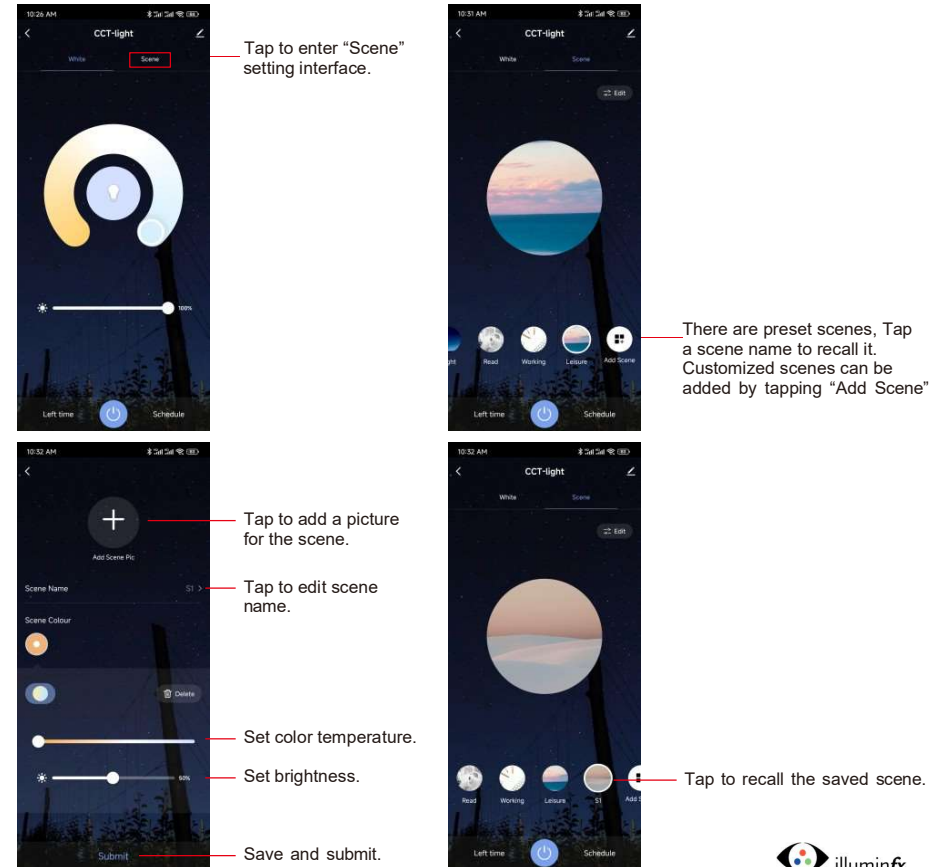

Step 6: Schedule Setting.



Tap to enter "Schedule" setting.



Tap to add a schedule.



The light will turn on after the count down time elapses.

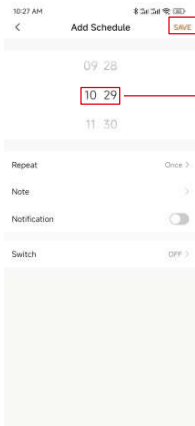

Tap to save the schedule.

Scroll to set a schedule time.

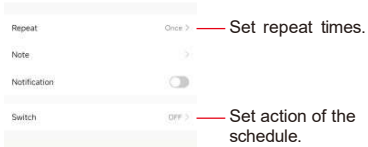

Set repeat times.

Set action of the schedule.

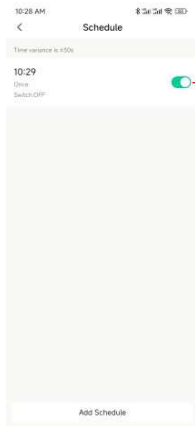

A schedule is set successfully. When the set time elapses, the set action will be executed.

Step 7: Left time Setting.



Tap to enter "Left time" setting.

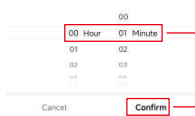
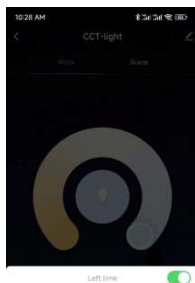

Scroll to set a count down time.

Tap to confirm the setting.

3. Remove the WiFi LED controller from the APP interface.

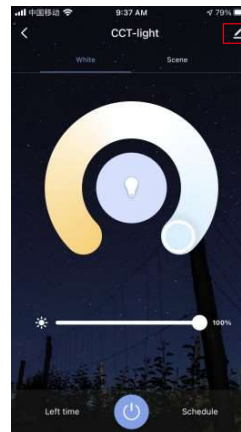

Tap to enter device edit interface.

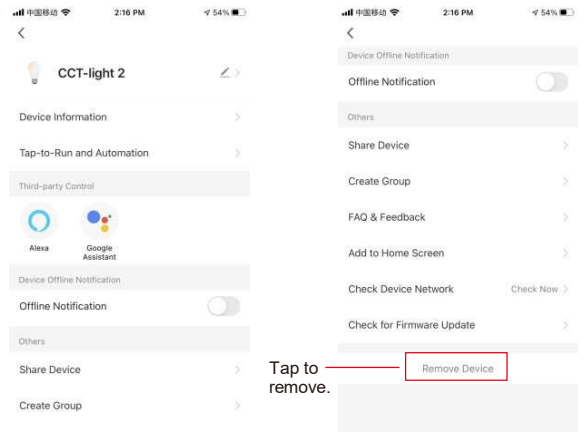

Tap to remove.

4. Pair the LED Controller with an RF Remote (please refer to user manual of corresponding RF remote)

Step 1: activate the RF remote by short pressing ON button.

Step 2: select a zone on the RF remote by short pressing the zone number if it is a multi-zone remote.

Step 3: short press "Prog." key on the LED controller (or reset power 3 times) to set it to RF pairing mode.

Step 4: immediately touch the color wheel or short press any other button except on/off button on the remote.

Step 5: LED lights connected with the controller blinks once to indicate successful pairing.

5. Delete Pairing to RF Remotes

Step 1: press and hold the "Prog." button for over 3 seconds until the connected LED lights blink, which means the pairing is deleted successfully.

6. Master and Slave Setting:

1. The receiver has both master and slave functions which can be set with a jumper. Short circuit of the jumper means master function, and open circuit means slave function. Once short circuit the jumper on a receiver, please power off and power on the receiver to enable master function. Setting master and slave enables perfect synchronization of color changing effects.

2. Set one receiver as master and pair it to any zone of a remote, and this zone shall only have one receiver which works as master. Set all other receivers as slave and pair them to other zones of the remote, and multiple receivers can be paired to each zone. Then choose all zones on the remote and play the color changing effects, the master will send sync signal to the slaves to achieve perfect synchronization. The max. sync distance between the master and any slave is within 30m.

7. PUSH DIM:

While connected with PUSH LV, click the button to switch ON/OFF lights. Press and hold down the button to increase/decrease light intensity.

Wiring Diagram

RGB+CCT Mode

1) When total load of each receiver is not over 20A

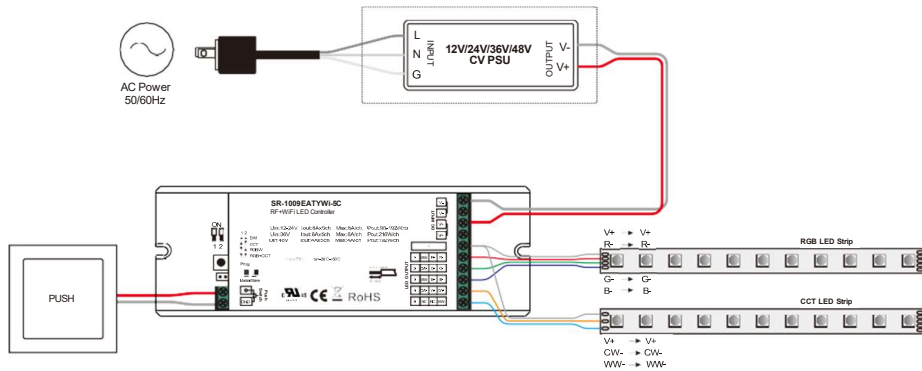

2) When total load of each receiver is over 20A

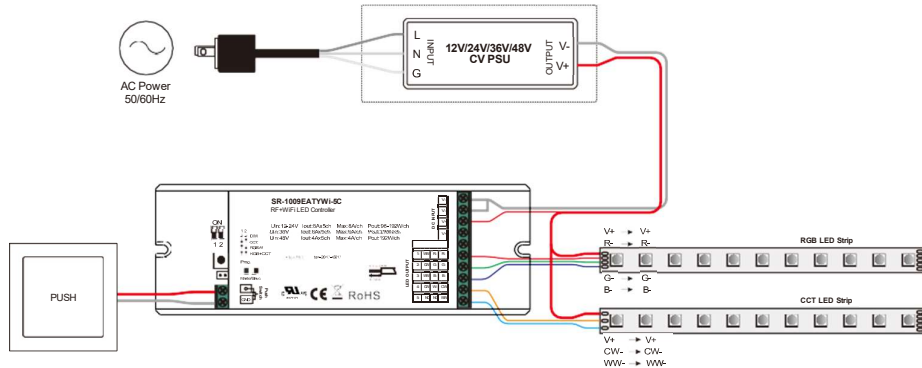

Note: please make sure the dial switches are at position for RGB+CCT mode as shown in above diagram.

RGBW Mode

1) When total load of each receiver is not over 20A

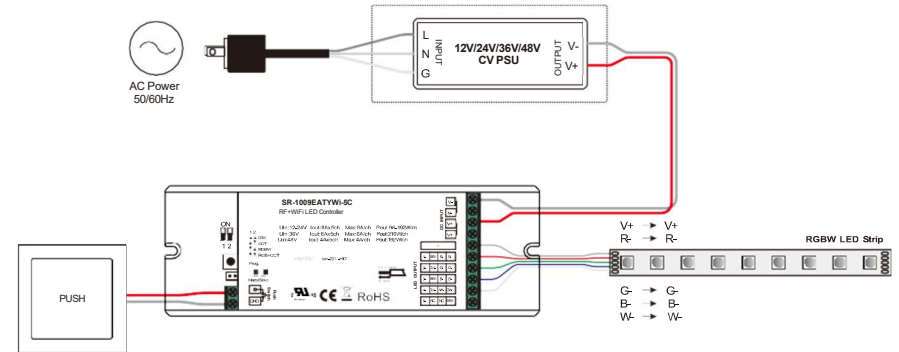

2) When total load of each receiver is over 20A

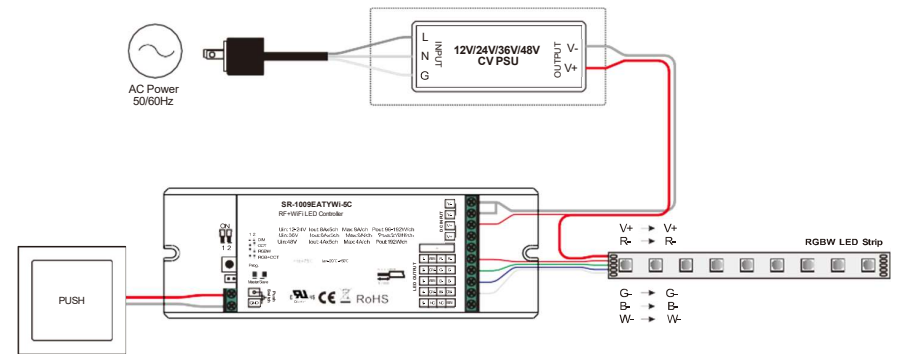

Note: please make sure the dial switches are at position for RGBW mode as shown in above diagram.

CCT Mode

1) When total load of each receiver is not over 20A

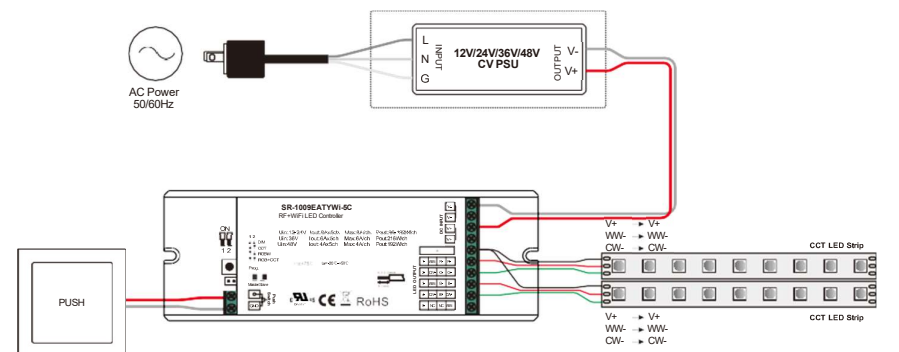

2) When total load of each receiver is over 20A

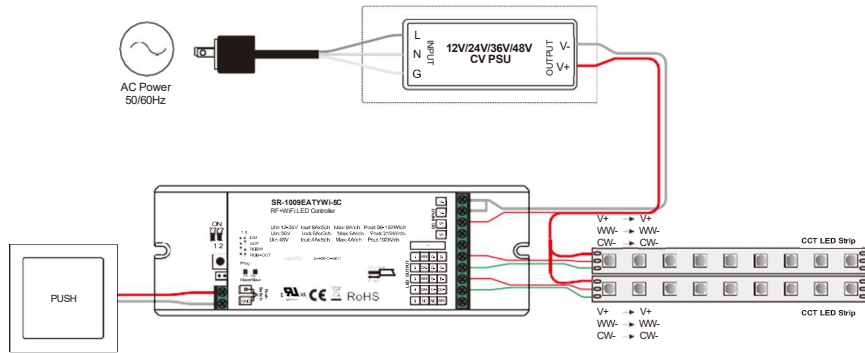

Note: please make sure the dial switches are at position for CCT mode as shown in above diagram.

DIM Mode

1) When total load of each receiver is not over 20A

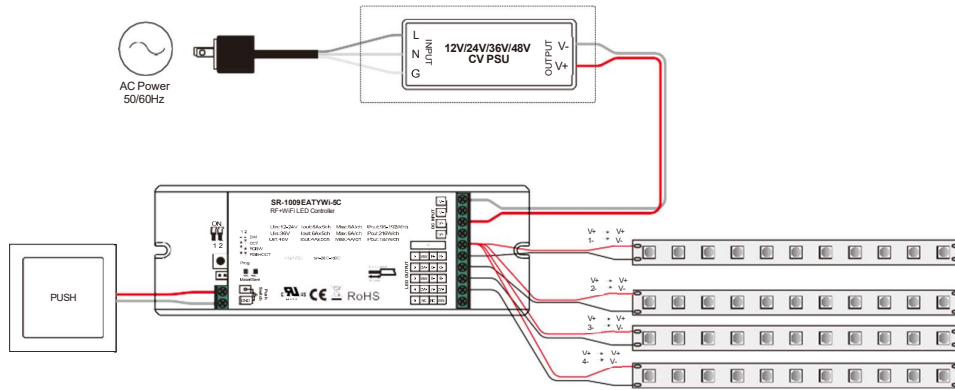

2) When total load of each receiver is over 20A

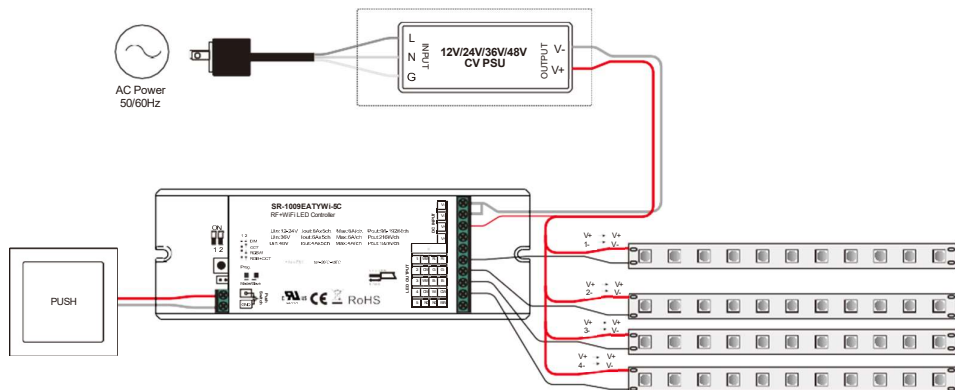

Note: please make sure the dial switches are at position for DIM mode as shown in above diagram.

Product Dimension

